



PREMIER SLAB 24 x 24 PAVERS

The possibilities are endless for this smooth cleaned paver. Use them individually as stepping stones or combine them to create continuous surfaces such as patios or pathways.



POSITANO
SMOOTH



TORINO
SMOOTH



OCEANSIDE
SMOOTH



BODEGA DUNES
SMOOTH

HAVE QUESTIONS?
Call 800-776-6690

PREMIER SLAB 24 x 24

Interlocking Paving Stones

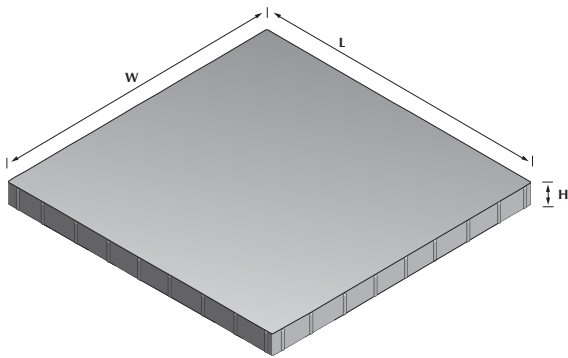

**PEDESTRIAN
USE ONLY**



REQUEST SAMPLES
Need product samples?
Contact us at 800-776-6690

Name	Metric Units	U.S. Customary Units	Height	Weight	Chamfer Width	Sq. Ft./ Pallet	Units/ Pallet	Weight/ Pallet
24 x 24	594mm W x 594mm L x 60mm H	23.54" W x 23.54" L	60mm	106 lbs	3mm	123	32	3442 lbs

605 Industrial Way
Dixon, CA 95620
800-776-6690

11888 West Linne Rd.
Tracy, CA 95376
800-776-6690

1201 Golden State Blvd.
Selma, CA 93662
559-896-0735

