



Customize products to suit your project. Basalite can create a custom hue just for you or select a paver color from our palette designed specifically for architects and designers.

[SEE COLORS](#)



**FINISHES & PATTERNS**

Customize products to suit your project. To see patterns, specialty aggregates Stay-True™ Technology and finishes [Click Here](#)



**REQUEST SAMPLES**

Need product samples? Email us at [commercialpavers@basalite.com](mailto:commercialpavers@basalite.com) or call 1-800-776-6690.



**TECHNICAL DOCUMENTS**

To see case studies, specifications and paver cross sections [Click Here](#)

# HAVE QUESTIONS?

Call 1-800-776-6690 or email  
commercialpavers@basalite.com

# PLANK PAVER

Interlocking Paving Stones

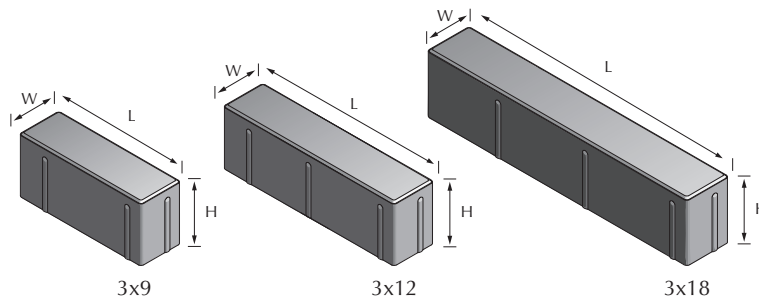

NAME	METRIC SIZE	U.S. SIZE	HEIGHT	APPLICATIONS			ARCHITECTURAL FINISHES					CHAMFER WIDTH	SQ.FT./PALLET
							STANDARD	GROUND FACE	SHOT BLAST	SHOT BLAST GROUND FACE	TUMBLED		
3x9	73mm W x 223mm L	2.87" W x 8.78" L	100mm	x	x	x*	x	x	x	x		3mm	75.6
3x12	73mm W x 298mm L	2.87" W x 11.73" L	100mm	x	x	x*	x	x	x	x		3mm	77.2
3x18	138mm W x 448mm L	2.87" W x 17.64" L	100mm	x			x	x	x	x		3mm	60

For design consideration add 1.5mm or .06" to the W and L dimensions to allow for the spacers.

\*Ideal size/thickness for pavements designed to handle heavy vehicles such as transports, buses and fire trucks.



### PEDESTRIAN

Indicates product is suitable for projects with pedestrian use.



### LIGHT-DUTY VEHICULAR

Indicates product is suitable for light-duty vehicular projects like driveways and parking stalls.



### COMMERCIAL VEHICULAR

Indicates product is suitable for commercial vehicular projects like parking lots and roadways.



605 Industrial Way  
Dixon, CA 95620  
800-776-6690

11888 West Linne Rd.  
Tracy, CA 95376  
800-776-6690

1201 Golden State Blvd.  
Selma, CA 93662  
559-896-0753

FOLLOW US

